



Curved Secondary Mount

Installation Instructions and User Manual

Rev. 2/13

For solid tube telescopes up to 15.0" inside diameter.

General Information



ProtoStar curved secondary mounts are designed to eliminate diffraction spikes by removing straight edges obstructing the aperture. The 180° angle of bend symmetrically spreads diffracted light rendering it nearly invisible. The thin arch material (about 0.6 mm thick in most places) and short path length produces the *lowest total diffraction* of any curved design. (The total diffraction for the **ProtoStar** curved mount is about the same as our 4-vane spider.)

Design Features:

- ❑ **Tapered-width arch.** The efficient double-cantilever design keeps the arch thin and lightweight.
- ❑ **Laminated metal arch construction.** Larger arch sizes are laminated sheets of stainless steel, which increases rigidity while keeping thickness to a minimum.
- ❑ **Fully adjustable arch design.** The mounting brackets permit fine positioning adjustments of the secondary mirror within the tube, as well as secondary offset.

Before you start

Remove all optics from the telescope. To prevent damage to your optics from falling parts and tools, remove the primary mirror from the telescope. The mirror holder should also be removed from the arch assembly during installation.

Choose the orientation you want. The **ProtoStar** curved support can be oriented in two ways as shown in **Figure 1**. In most cases the top-mounted orientation is preferable. When the arch is top-mounted, no part of the arch is visible from the vantage point of the focal plane. (Reflected light from the support structure is eliminated.) In some cases, other accessories (finder scopes, etc.) may interfere with this location, so the bottom-mounted orientation must be used.

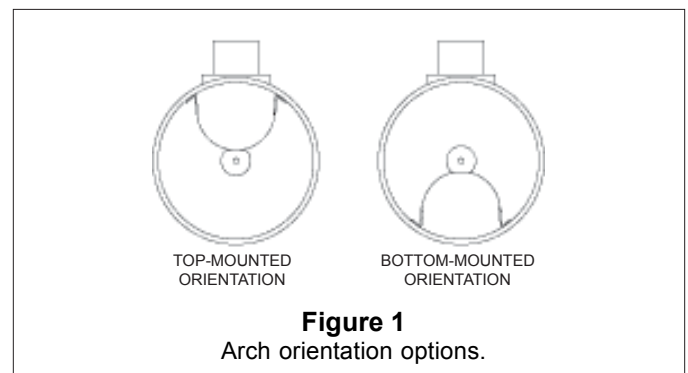

Figure 1
Arch orientation options.

Installation Instructions

Required Tools. You will need the following tools:

- flat screwdriver
- Phillips screwdriver
- ruler
- pencil
- scissors
- tape

Step 1 Mark the bracket centerlines.

Temporarily attach the two mounting brackets to the arch support using the supplied #6 screws and nuts. The fasteners only need to be finger-tight. With the bracket feet facing outward (see **Figure 2**), compress the arch enough to make the bracket feet sit flat on the tube wall. While holding the arch in this position, make pencil marks on the end of the tube that correspond to the small notches on the ends of the brackets. It is not important to position the arch with high precision, as you will accurately position the secondary mirror in a later step.

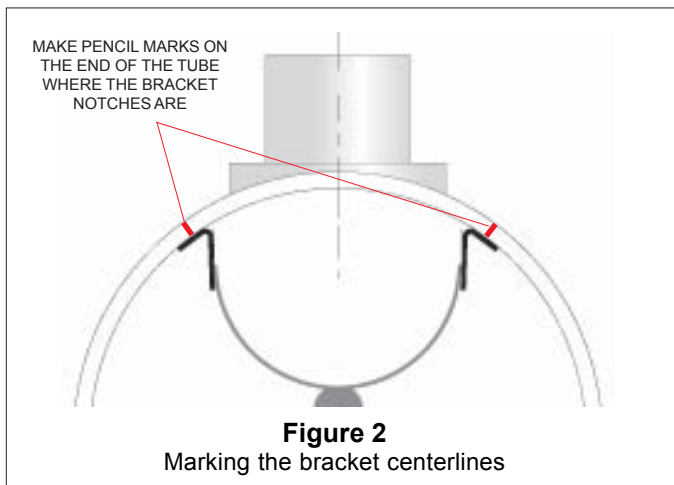

Step 2 **Mark the bracket centerlines on the tube.** Using a straight edge, draw two pencil lines down the outside of the tube starting at the marks you made in the previous step. The lines need to be long enough to go past the focuser base by an inch or two as shown in **Figure 3**.

Step 3 **Apply the drilling template.** Tape the paper drill template to the tube as shown in **Figure 4**. Align the template's long axis with one of the lines you just drew on the tube. By sight, line up the centerline that corresponds to your secondary mirror holder's size with the center of your focuser drawtube.

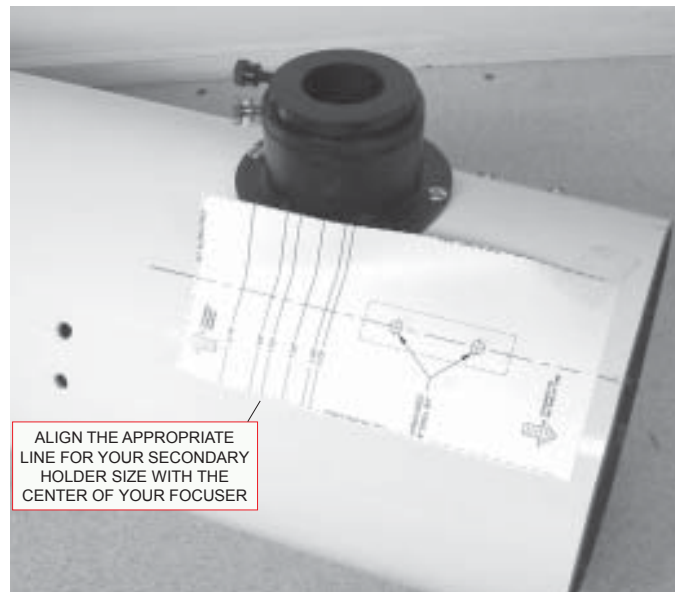

Using the paper template to lay out the bracket holes.

Step 4 **Drill the bracket mounting holes.** Mark the bracket hole positions, and drill using the supplied drill bit. Repeat Steps 3 and 4 for the second bracket.

Step 5 **Mount the brackets to the tube.** Install the mounting brackets using the #8 screws and flange nuts, but do not fully tighten the nuts.

Step 6 **Permanently install the arch to the brackets.** Remove the #6 screws holding the arch to the brackets, and remove the arch. Note that the brackets have three positions for the tangs at the feet of the arch to snap in to. This allows for precise positioning of the secondary mirror within the tube. Find the best position for the arch that best positions the secondary mirror within the tube. Reinstall the #6 fasteners, and fully tighten (see **Figure 5**).

Step 7 **Edge-on arch adjustments.** The #8 screws holding the brackets to the tube should still be only finger tight. By sighting down the tube from a

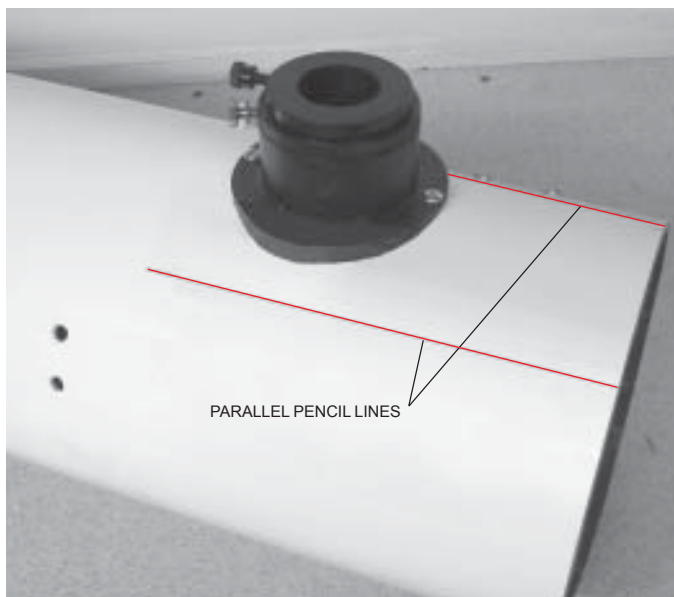

Drawing the bracket centerlines on the tube.

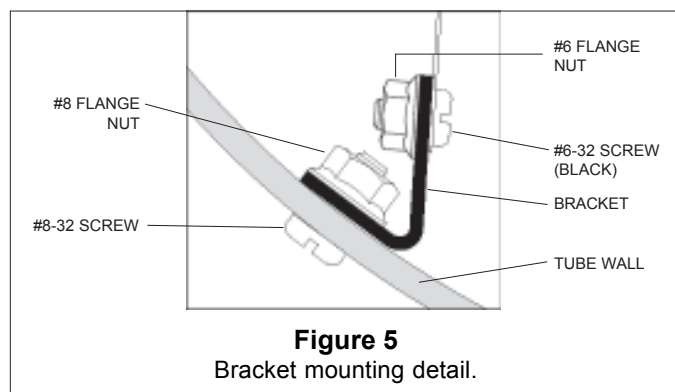

few feet away, check to see if the arch silhouette appears edge-on. Make adjustments by twisting each side of the arch until it appears the thinnest. (One of the bracket holes is elongated to permit the bracket to rotate.) When you are satisfied with the appearance, tighten the bracket mounting screws.

Step 8 Install the Secondary Mirror.

Important Note: If your secondary mirror is the same size as the holder, it can be installed using the metal shroud. In some cases, mounting the mirror with an adhesive will be necessary:

- (1) Our 0.75" and 1.00" holders are not supplied with a shroud, so the glue method is used.
- (2) Many imported secondary mirrors are not the size of our holders, so gluing is required.
- (3) Most secondary mirrors are from glass castings and frequently slightly oversized. This results in an interference fit with the metal shroud which will optically distort the mirror. If your mirror doesn't seem to fit inside the shroud properly, you should glue it in place. (*Protostar* mirrors are CNC-machined to the correct size to prevent this problem.)

Method #1: Install the Secondary Mirror With the Shroud

Lay the foam mirror pad (paper side down) and mirror in place on the diagonal head face. Slip the shroud onto the diagonal holder, and loosely install the shroud retaining screws. Position the shroud onto the mirror until the tabs lightly contact the mirror surface. **Do not push the shroud too tightly against the mirror, or you may deform the optical surface.** Tighten the shroud retaining screws. The final installation should look like **Figure 6**.



Figure 6
Mirror mounted with shroud.

Method #2: Install the Secondary Mirror With Adhesive

The secondary mirror can be glued directly to the face of the *Protostar* holder as long as there is a small gap left between the back of the mirror and the holder face. (Your kit includes three small spacer washers

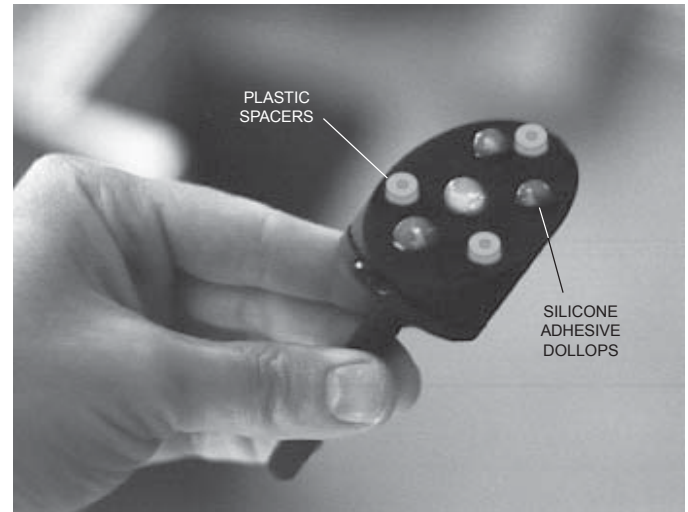

Figure 7

Spacer and adhesive layout.

for this purpose.) Glue the three plastic spacers to the holder near the edge as in **Figure 7**. After the spacers are in place, glue the secondary mirror on. Use silicone adhesive only. These are commonly available from hardware stores (GE Silicone II®, Dow Corning 733®, Devcon® Silicone Rubber, etc.). It's best to use a fresh tube, as there is a catalytic component that evaporates with time. Make sure both the mirror and holder face are clean and oil-free. Let the adhesive cure for 24 hours in a room temperature environment.

Step 9 Install the secondary holder to the arch.

Turn the hub collimation screws clockwise until they protrude by about 1/8" (2 mm). Insert the secondary holder into the hub on the arch, and visually ensure that the three collimation screws are engaged into the dimples on the clutch disk. The dimples prevent the mirror holder from rotating when you turn the collimation screws. Finger tighten the stem nut.

Now, you are ready for the initial collimation...

Collimation

All *Protostar* secondary mounts use the same principal for collimation. The stem of the secondary holder needs to be slightly stretched in order to hold proper collimation. Tension in the stem is created by tightening the tensioning nut as shown in **Figure 8**, or by turning the collimation screws clockwise.

Collimation should always be done in the following order; **1)** center the secondary mirror under the focuser using a sight tube, **2)** tilt adjustment of the secondary mirror, and **3)** tilt adjustment of the primary

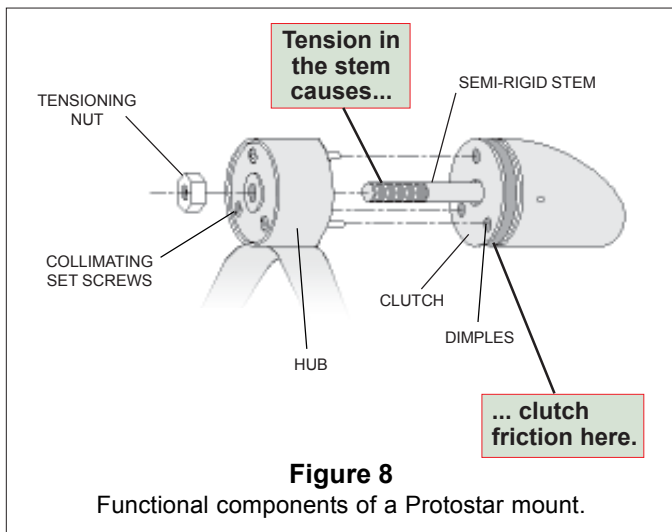

mirror. When doing the first collimation of a newly-assembled telescope, it's almost always necessary to repeat these steps several times. If repeating the process is necessary, always go back and repeat steps 1 through 3 in order. Consult the instructions that came with your collimation tools on how to use them.

Center the secondary under the focuser

To move the secondary closer to the primary mirror, first loosen (counterclockwise) the tensioning nut a half turn, and then tighten (clockwise) the three collimation screws until you feel resistance (make sure they remain aligned with the clutch dimples). Repeat as necessary.

To move the secondary away from the primary mirror, first loosen (counterclockwise) the three collimation screws by about one turn each, and then finger tighten (clockwise) the tension nut until it is snug. Repeat as necessary. Positioning the secondary axially may take several repetitions, but keep in mind you only need to do this for the very first collimation. Subsequent collimation will go much faster.

Lateral centering adjustments (i.e., 90-degrees to the axial adjustments) is accomplished by either tilting the focuser with shims (some focusers have built-in miniature jack screws in the base just for this purpose), or by adjusting the position of the arch tangs in brackets.

Tilt adjustment of the secondary mirror

Start the tilt adjustment with the tensioning nut only finger tight. If most of your subsequent turns of the collimation screws are clockwise, this is usually

enough to tighten and lock the system in place with no further action (i.e., you do not need to tighten the main nut as a final “lock down”). If you find the secondary holder is still too loose, you can manually tighten the tensioning nut another half turn. Do not tighten the tensioning nut more than is needed to just keep the holder from rotating freely. The secondary mount is designed to hold collimation with very little friction and tension in the system.

Technical Support

We want your **Protostar** product to perform well in the field. If you have a special application not covered in these instructions or any other questions, feel free to call us for technical support at (614)-855-5341 between 9:00 AM and 5:00 PM (Eastern Time Zone).